



IMS Impacts on SIP

Jonathan Cumming
Director, VoIP Product Management

Use of SIP in IMS

- Replacement signalling for calls, messaging and presence
 - Chosen for its
 - Flexibility
 - Abstraction between layers
 - Ease of function distribution

- SIP was initially designed for the Internet



Open homogeneous IP network

- But telephone networks are different

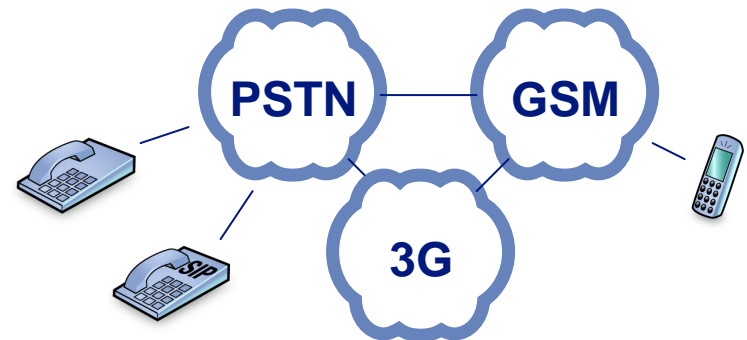

Different Business Model

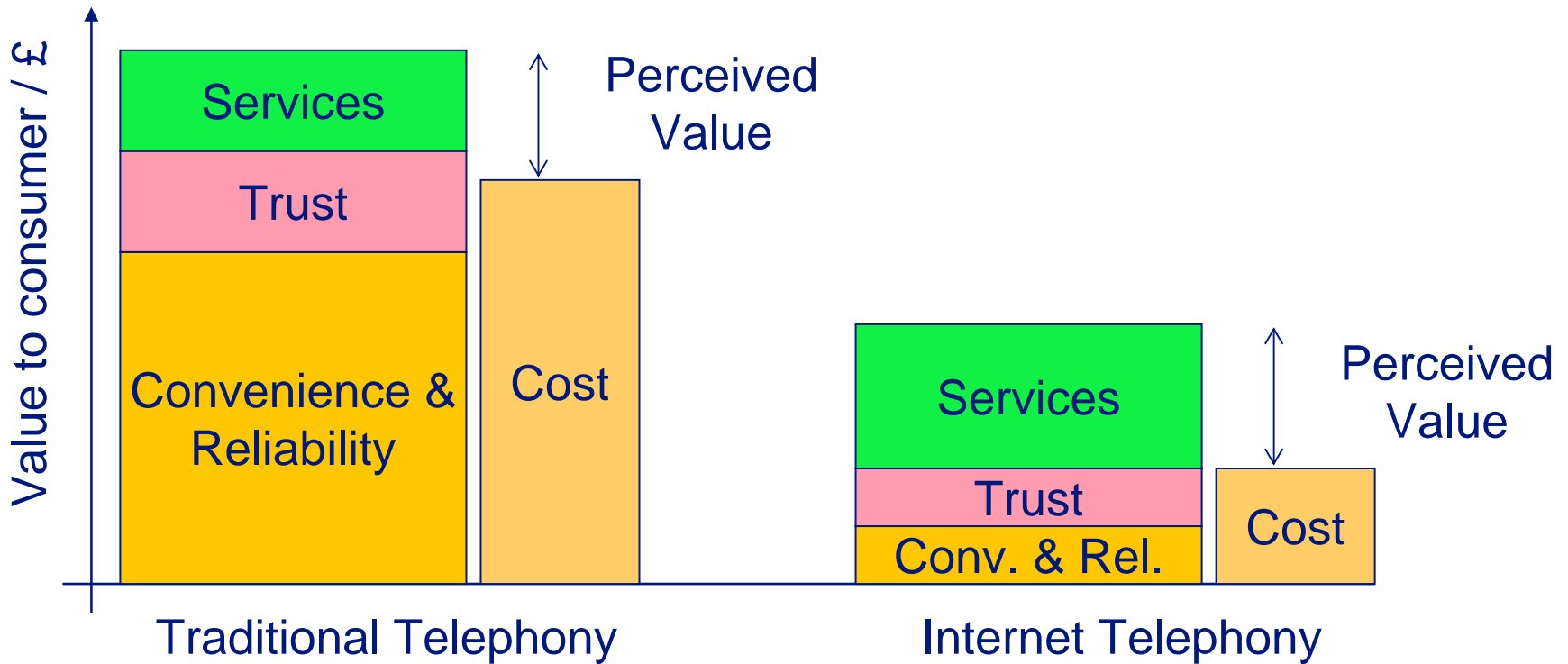

Business compete by offering more value than they cost, not by being cheaper.

IMS Requirements

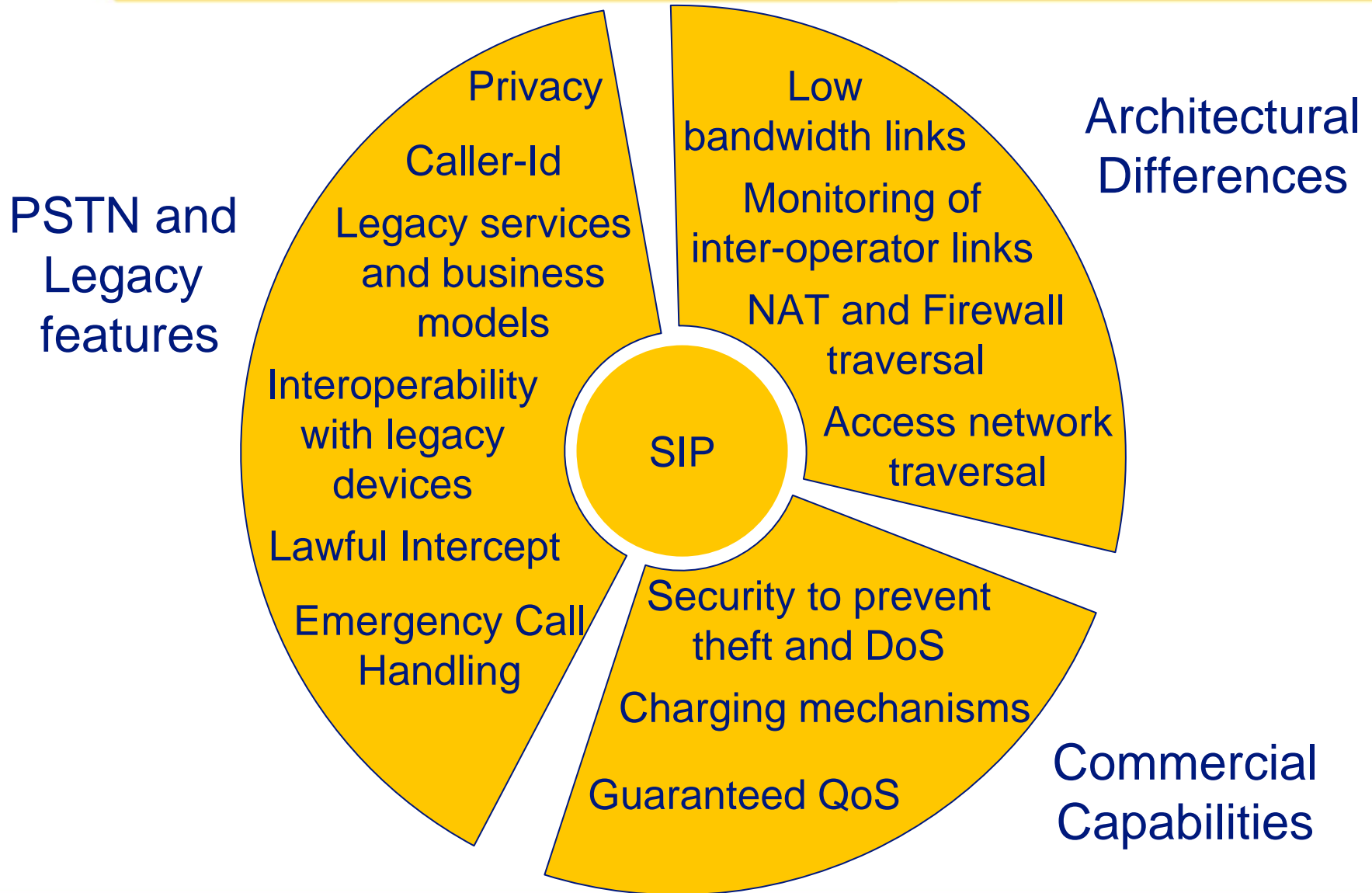

IMS Requirements



Typical SIP scenario

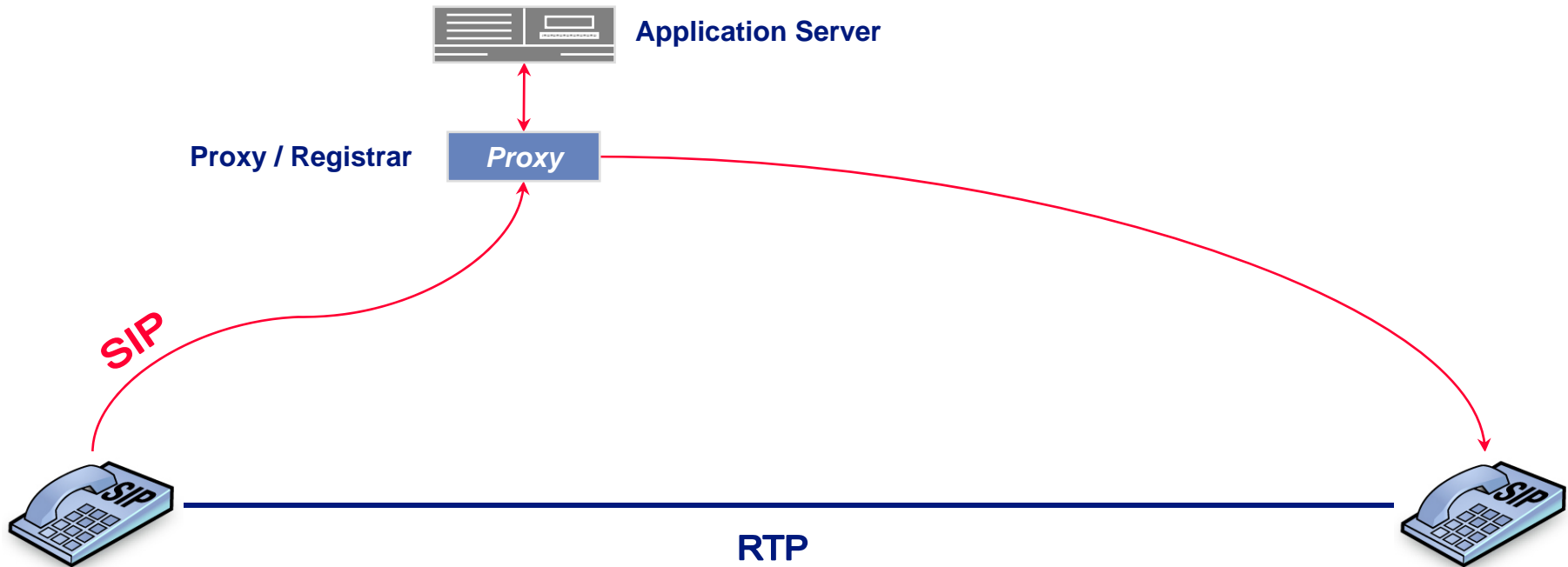

- Signalling may be routed via proxies to provide address resolution
- Media routed directly across the Internet

IMS introduces Trusted Core and Untrusted Access

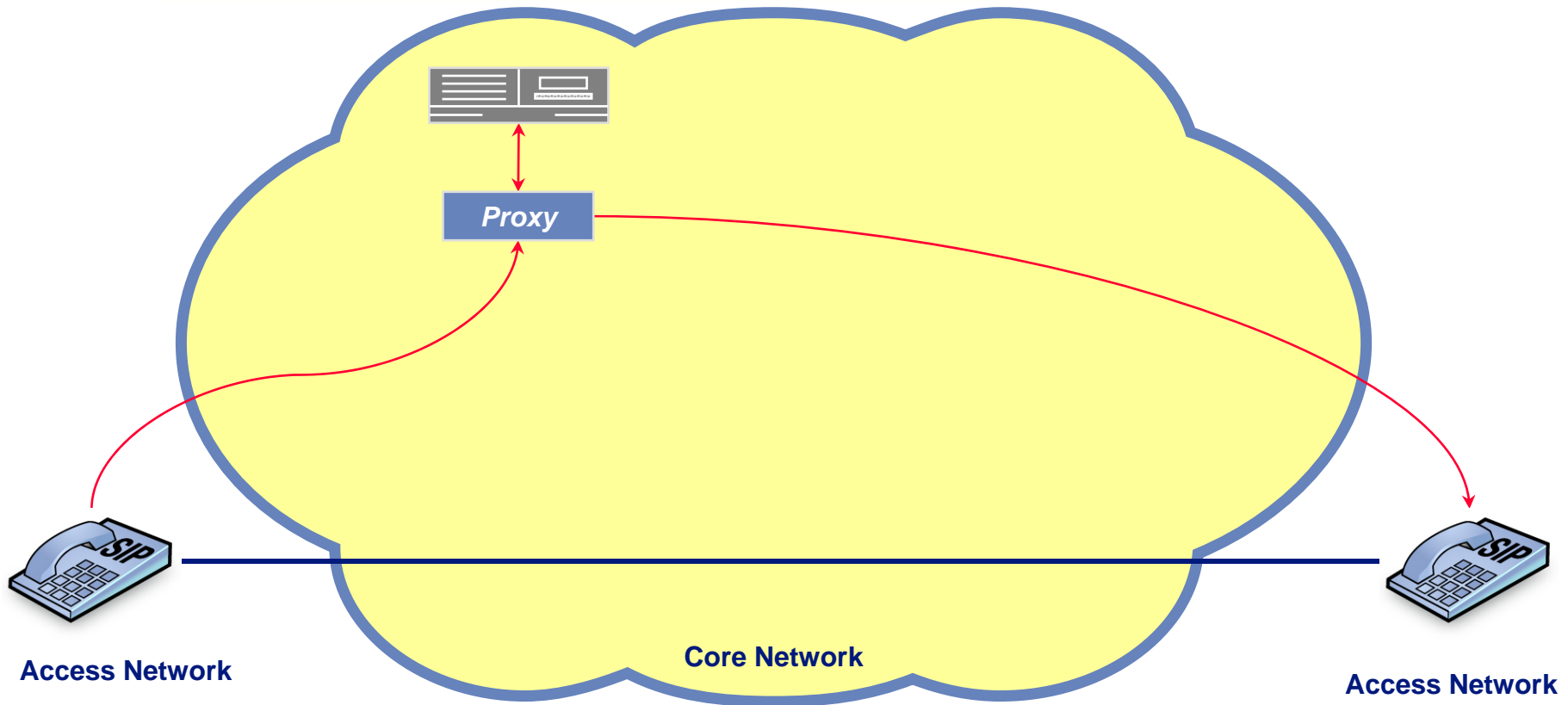

- Operator-managed core network
 - Responsible for service end-to-end
 - QoS guaranteed, SLAs monitored

IMS introduces Trusted Core and Untrusted Access

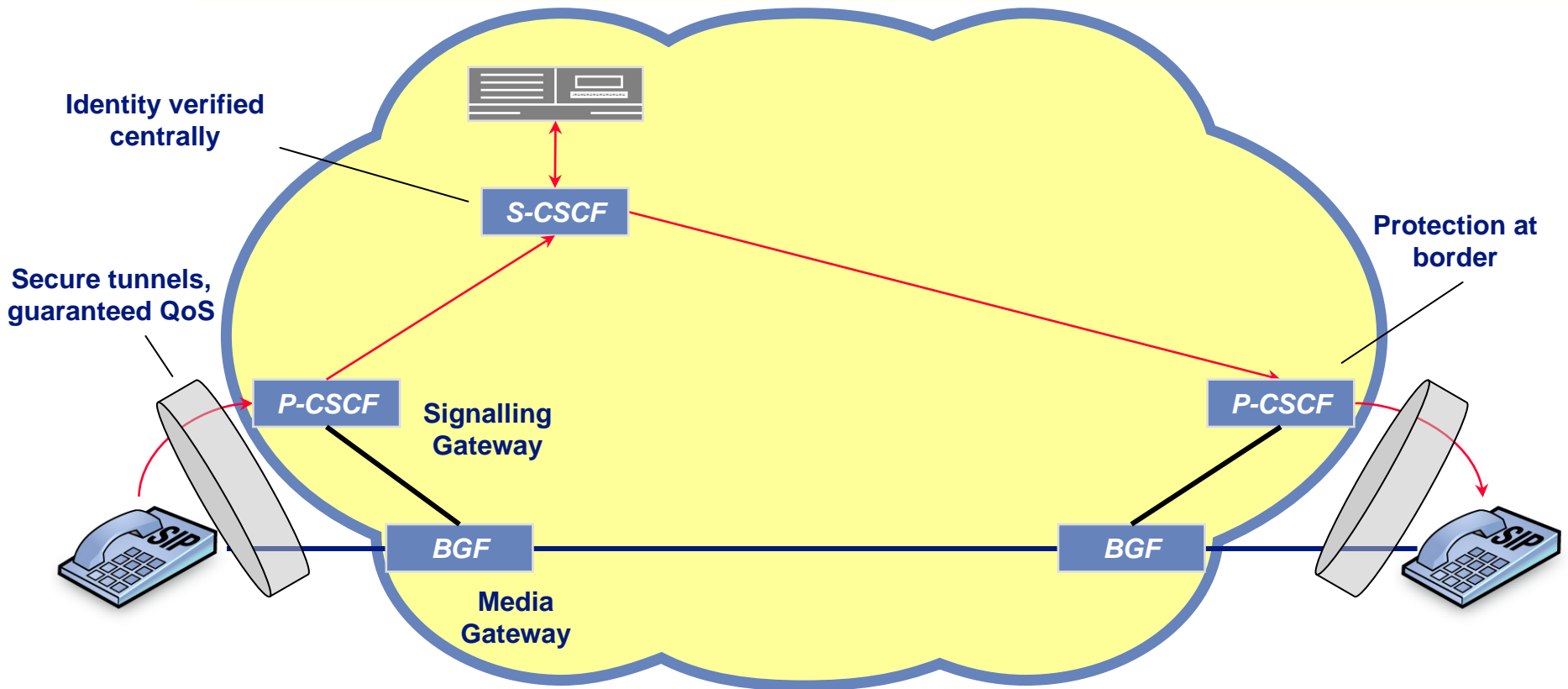

- Access control enforced by P-CSCF and Media Gateways
 - Media reservation, Identity management

Multiple carriers involved

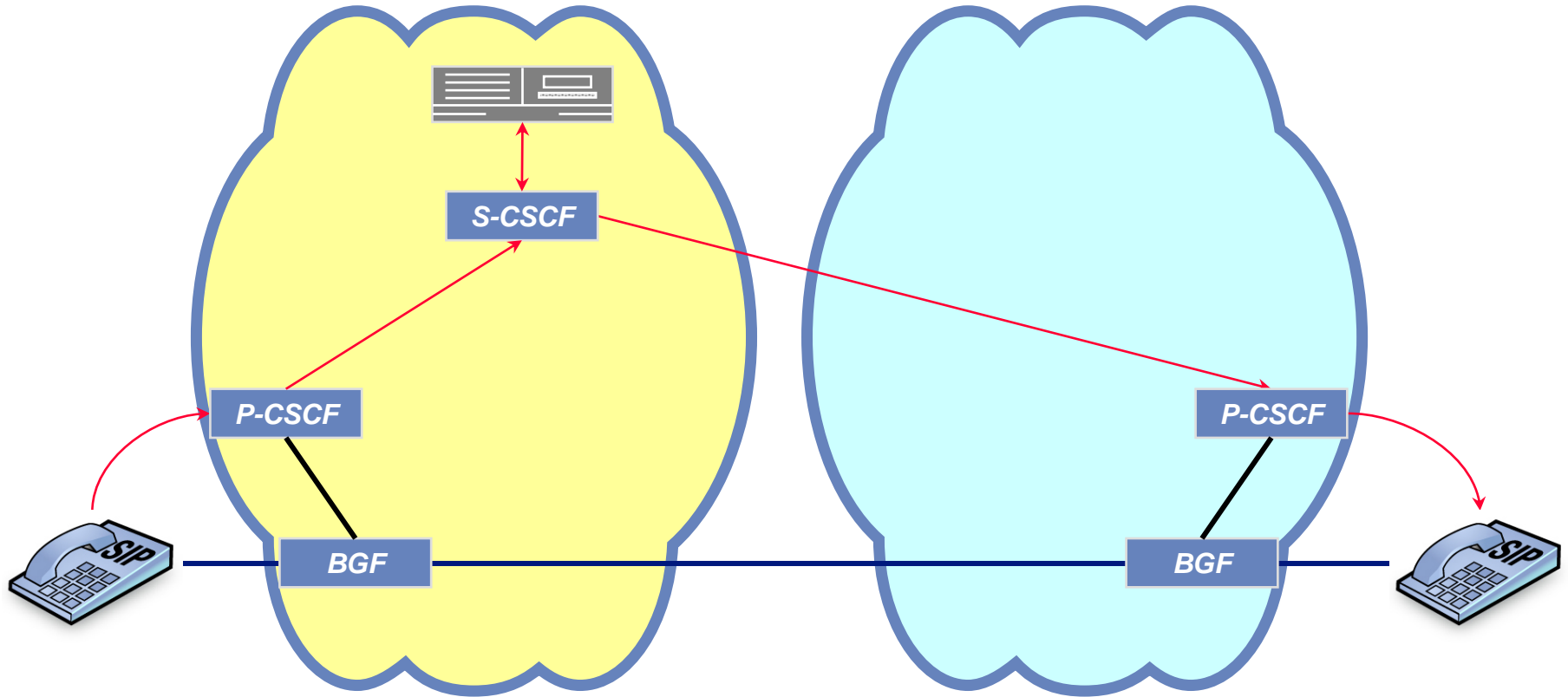

Multiple carriers involved

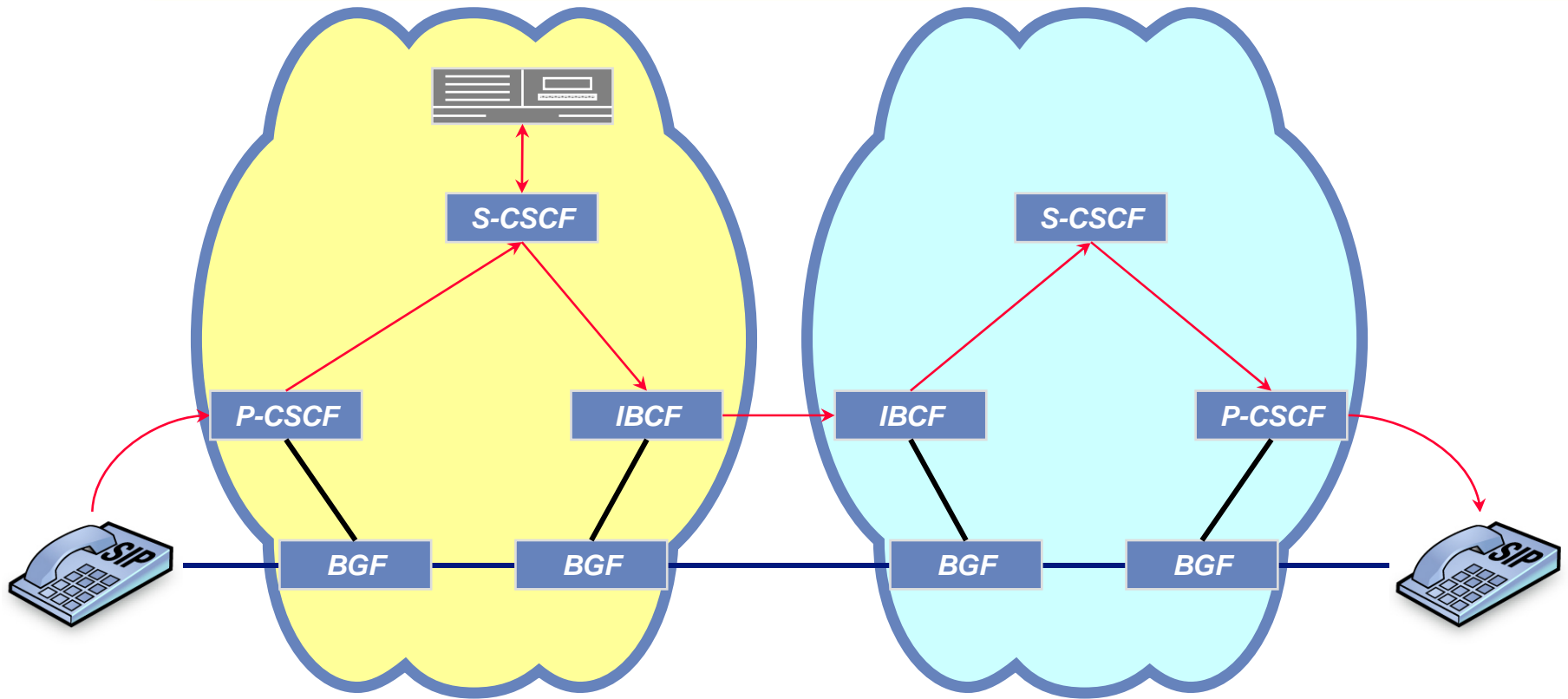

- Limited trust at border
 - Inter-carrier traffic monitored and controlled
 - Protocol interworking, e.g. H.323 and non-IMS SIP

Central identity management

- Strong mutual authentication using SIMs and AKA
 - Security Agreement (RFC 3329)

Security validation occurs on SIM card



User credentials
calculated by server
Challenge
Expected SIM response
Expected response

- Centrally-validated identity (P-Asserted-Identity)
 - Traceability for emergency calls and call-back
 - Identity removed at border to maintain privacy

- Support for multiple identities

- P-Associated-URI
- P-Preferred-Identity
- P-Called-Party-ID

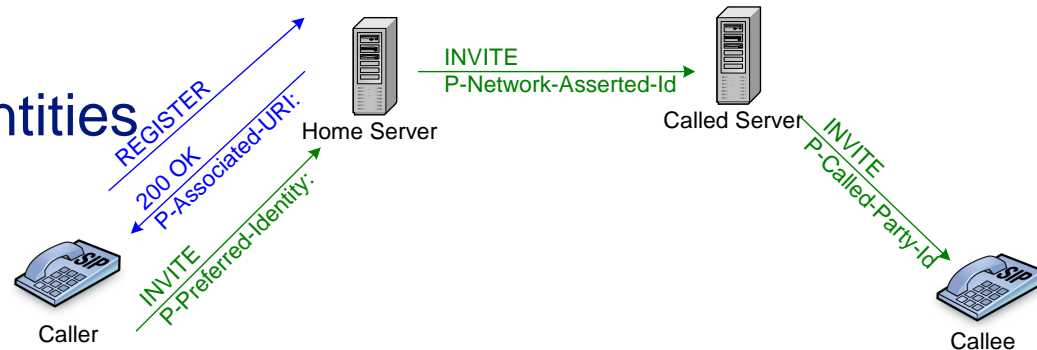

Access control enforced at border

- Centrally-controlled routing of signalling
 - Path (RFC 3327)
 - Service-Route (RFC 3608)

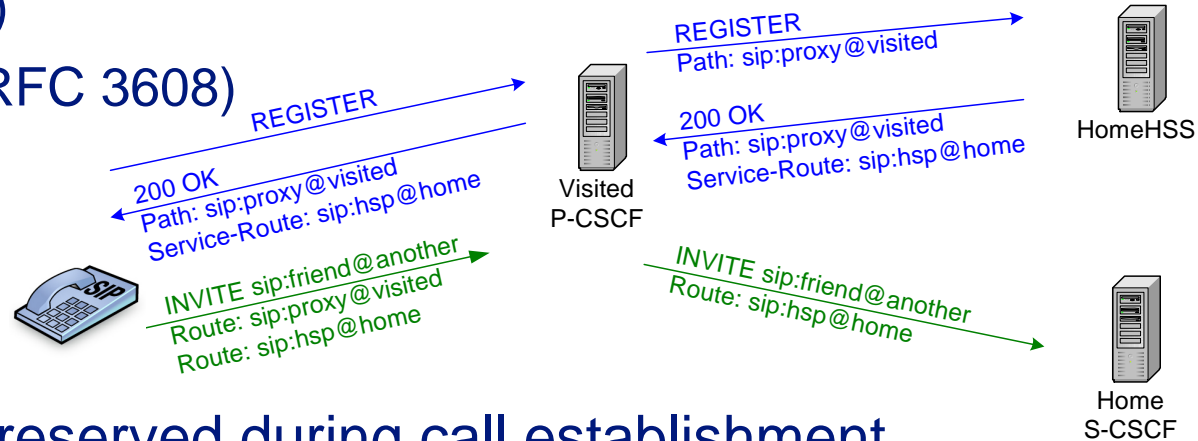

- Media bandwidth reserved during call establishment
 - Preconditions
 - P-Media-Authorization

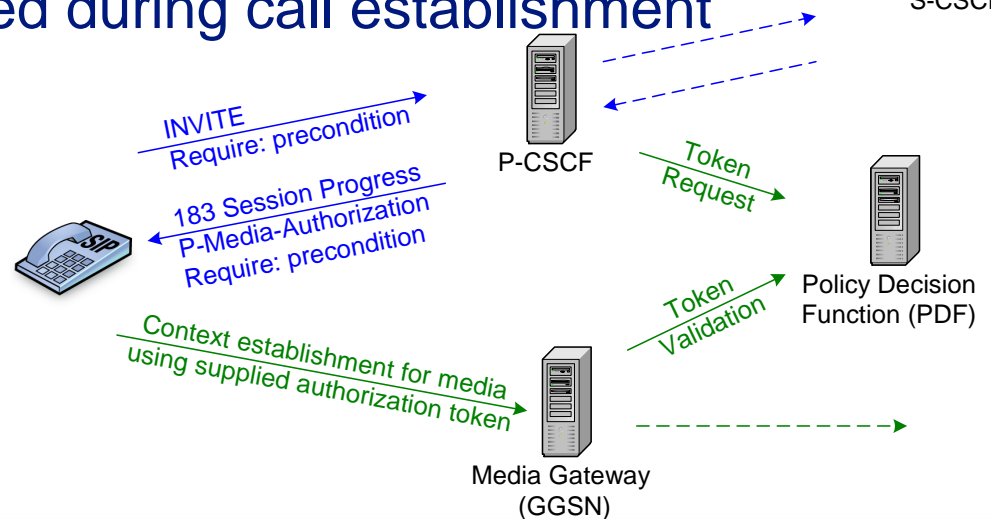

Commercial capabilities

- Billing information returned by many devices
 - Billing Correlators passed in signalling
 - P-Visited-Network-ID
 - P-Charging-Vector
 - P-Charging-Function-Addresses

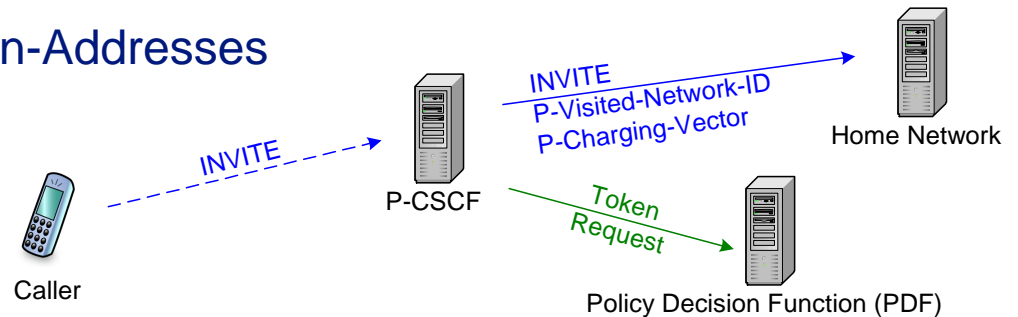

- Optimisations for low bandwidth links
 - Signaling compression (RFC 3320)
 - P-Access-Network-Info allows application to adapt

What is the impact on SIP?

- SIP extensions standardized as RFCs
 - IMS specific extensions defined as private (P-Headers)
- Operator requirements similar to enterprise requirements
 - Controlled access to network resources
 - Session Border Controllers protect enterprise border
 - Reduced network transparency limits service evolution
- IMS maintains operator control of the customer relationship
 - Allows operator to offer additional services
 - Operator can decide how much control to exert
- Battle is commercial, not technical

Non-IMS SIP calls may still be allowed

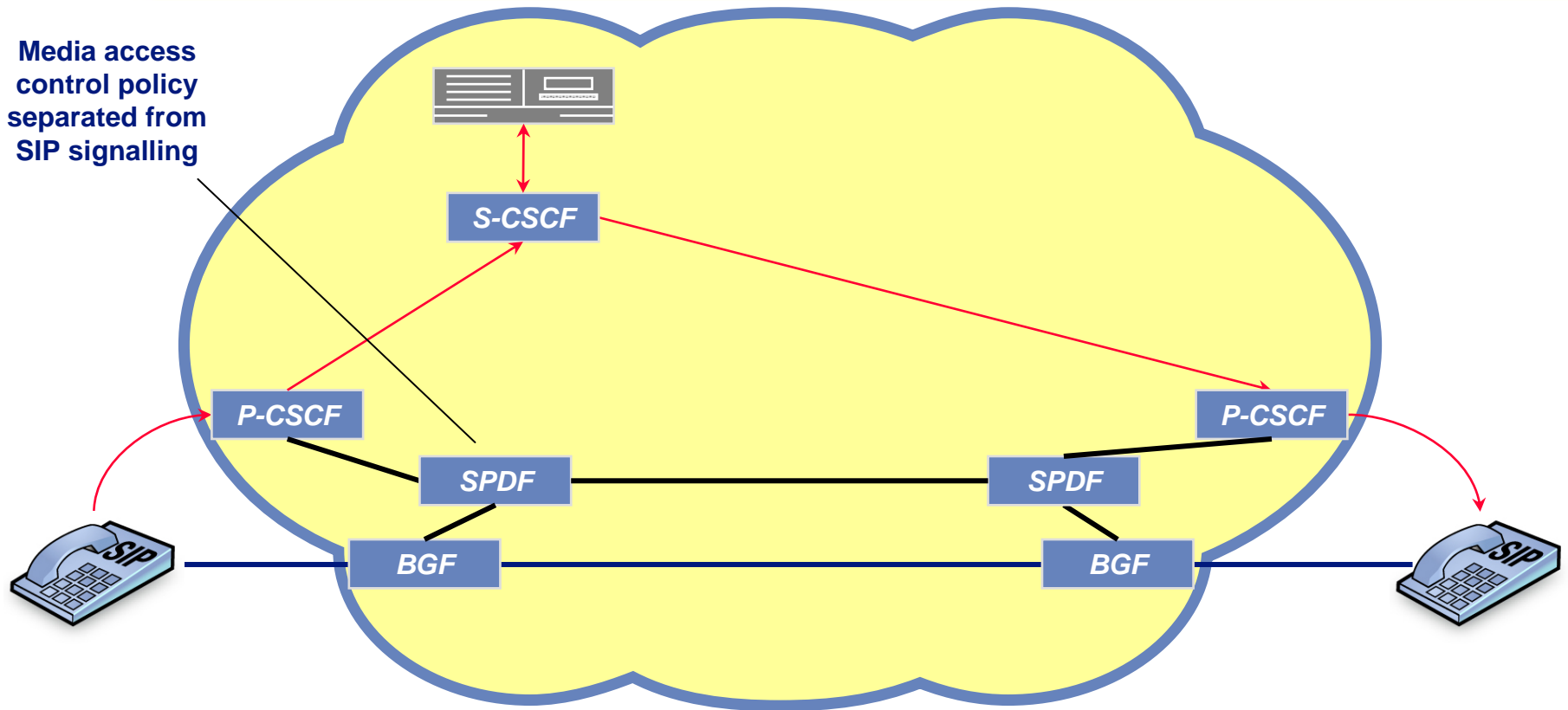

- Other protocols may signal media reservation, e.g. streaming
- Competition and additional mobile bandwidth will lead to different business models – including more open IP access

Resulting network architecture

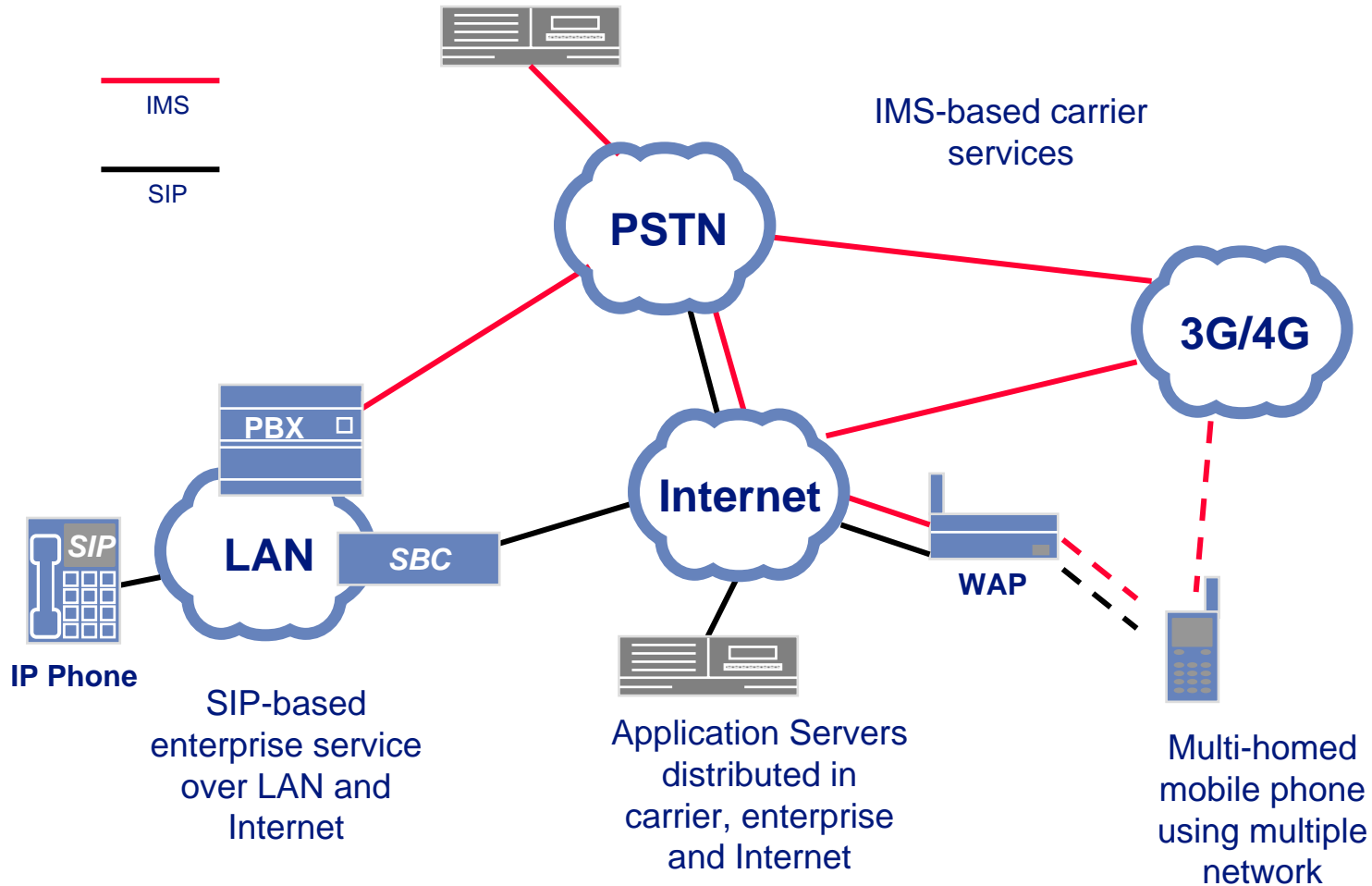

Developing products for IMS

- IMS-compliant SIP stack/toolkit, e.g. DC-SIP
 - SIGCOMP
 - AKA/MD5
 - IPv6
 - P-Headers
 - Non-standard behaviour – e.g. proxy can release calls
- Enhancements to application logic, e.g. DC-SBC
 - Application support for P-Headers and other extensions
 - IMS architecture – reference points to billing, policy, etc.
 - Protocol interworking between IMS and non-IMS variants

Summary

- IMS takes advantage of SIP's
 - Flexible distribution of function and scalability
 - Access-independent application platform
- IMS extends SIP to provide
 - PSTN-like features
 - Inter-carrier routing
 - Flexible charging mechanisms
- IMS introduces controls to
 - Protect against misuse, theft, and DoS
 - Check SLAs and charges
 - Hide private information
 - Handle NATs and firewalls
- Centralised design
 - Provides safe environment
 - Limits feature evolution
 - Defines approved services

IMS will be one part of the network

Not ideal for all applications: commercial, not technical battle

Data Connection (DCL)



Stable & Independent

- Privately held and profitable

Expert in Voice, Data and IMS

Supplier to the Industry

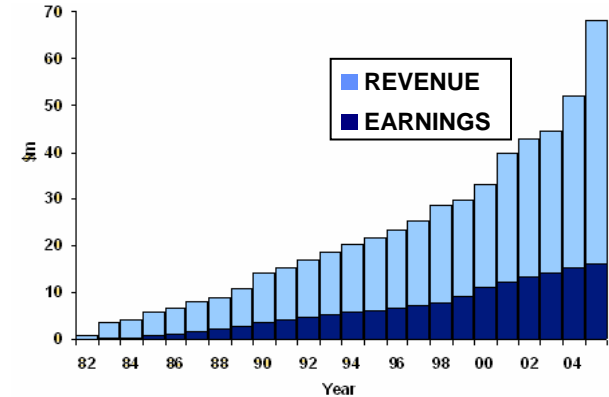

Worldwide leader in Networking Protocols

SIP, H.248 (Megaco), MGCP, SBC, IP Routing, MPLS, ATM



Messaging and Conferencing Solutions

**IMS Application Servers
Unified Messaging Applications**



Class 5 softswitch



Thank you for listening



jonathan.cumming@dataconnection.com